

## INDEX

P/N	PAGE
22111 ( BSP FEMALE MULTISEAL ) .....	2
22141(45°BSP FEMALE MULTISEAL).....	3
22191(90°BSP FEMALE MULTISEAL).....	4
22211(BSP FEMALE FLAT SEAL) .....	5
22241(45°BSP FEMALE FLAT SEAL) .....	6
22291(90°BSP FEMALE FLAT SEAL) .....	7
22611(BSP FEMALE 60° CONE).....	8
22611D(BSP FEMALE 60° CONE DOUGLE HEXAGON).....	9
22611-SM(BSP FEMALE 60° CONE DOUGLE HEXAGON).....	10
12611(BSP MALE 60° CONE SEAT).....	11
12611A(BSP MALE DOUBLE USE FOR 60° CONE SEAT OR BOUNDED SEAL)....	12
12211(BSP MALE O-RING SEAL).....	13
13011SP(BSPT MALE).....	14
29611(JIS FEMALE 60° CONE SEAT JIS B8363).....	15
29641(45° JIS FEMALE 60° CONE SEAT JIS B8363).....	16
29691(90° JIS FEMALE 60° CONE SEAT JIS B8363).....	17
72011(BSP BANJO).....	18
720B( BSP BOLT).....	19

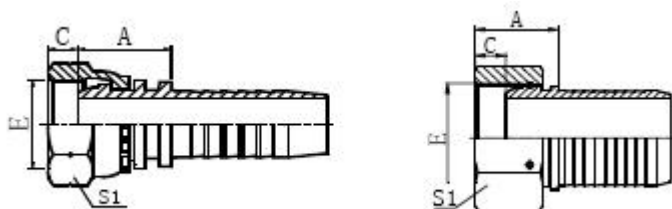

英管内螺纹球面

BSP FEMALE MULTISEAL

22111

22111-W

代号 P/N	螺纹 E THREAD E	软管 HOSE BORE		尺寸 DIMENSIONS		
		公称内径 DN	标号 DASH	A	C	S1
22111-04-04	G1/4"X19	6	04	19.5	4	19
22111-06-05	G3/8"X19	8	05	20	5	22
22111-06-06	G3/8"X19	10	06	20.5	5	22
22111-08-06	G1/2"X14	10	06	22.5	6	27
22111-08-08	G1/2"X14	12	08	23	6	27
22111-08-10	G1/2"X14	16	10	24	6	27
22111-10-10	G5/8"X14	16	10	25	8	30
22111-10-12	G5/8"X14	20	12	25	8	30
22111-12-08	G3/4"X14	12	08	25	9.5	32
22111-12-10	G3/4"X14	16	10	26	9.5	32
22111-12-12	G3/4"X14	20	12	26	9.5	32
22111-16-12	G1"X11	20	12	26.5	11	41
22111-16-14	G1"X11	22	14	26.5	11	41
22111-16-16	G1"X11	25	16	28	11	41
22111-20-16	G1.1/4"X11	25	16	30	10	50
22111-20-20	G1.1/4"X11	32	20	31.5	10	50
22111-24-24	G1.1/2"X11	40	24	33	11.5	55
22111-32-32	G2"X11	50	32	35	15	70

Note: 1. For use with braided hoses.  
2. If use with spiral hose, hose fitting series number is 22112-x x-x x

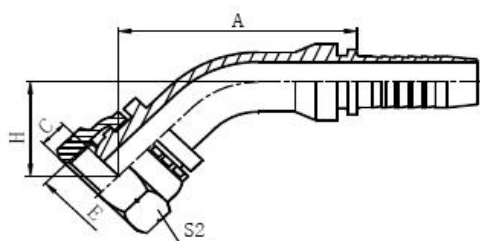

22141

45°英管内螺纹球面

45°BSP FEMALE MULTISEAL

代号 P/N	螺纹 E THREAD E	软管 HOSE BORE		尺寸 DIMENSIONS			
		公称内径 DN	标号 DASH	A	C	H	S2
22141-04-04	G1/4"X19	6	04	43.7	4	21.6	19
22141-06-05	G3/8"X19	8	05	46.2	5	22.9	22
22141-06-06	G3/8"X19	10	06	48.1	5	23.9	22
22141-06-08	G3/8"X19	12	08	60.4	5	25.4	22
22141-08-08	G1/2"X14	12	08	61.8	6	26.8	27
22141-10-10	G5/8"X14	16	10	73.7	8	28.9	30
22141-12-12	G3/4"X14	20	12	80.6	9.5	33.2	32
22141-16-12	G1"X11	20	12	81.6	11	33.5	41
22141-16-14	G1"X11	22	14	83.3	11	33	41
22141-16-16	G1"X11	25	16	89.2	11	35	41
22141-20-16	G1.1/4"X11	25	16	91.4	10	37.1	50
22141-20-20	G1.1/4"X11	32	20	103.4	10	41.2	50
22141-24-24	G1.1/2"X11	40	25	116.9	11.5	46.2	55
22141-32-32	G2"X11	50	32	137	15	54	70

Note: 1. For use with braided hoses.

2. If use with spiral hose, hose fitting series number is 22142-xx-xx

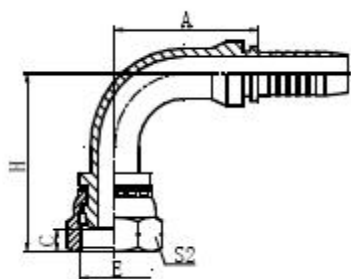

22191

90°英管内螺纹球面

90°BSP FEMALE MULTISEAL

代号 P/N	螺纹 E THREAD E	软管 HOSE BORE		尺寸 DIMENSIONS			
		公称内径 DN	标号 DASH	A	C	H	S2
22191-04-04	G1/4"X19	6	04	30	4	38.5	19
22191-04-05	G1/4"X19	8	05	33	4	41.5	19
22191-06-05	G3/8"X19	8	05	33	5	42	22
22191-06-06	G3/8"X19	10	06	35.3	5	44.8	22
22191-06-08	G3/8"X19	12	08	41	5	50	22
22191-08-06	G1/2"X14	10	06	35.3	6	46.8	27
22191-08-08	G1/2"X14	12	08	41	6	52	27
22191-10-10	G5/8"X14	16	10	56.5	8	57.5	30
22191-12-10	G3/4"X14	16	10	56.5	9.5	58.5	32
22191-12-12	G3/4"X14	20	12	65.5	9.5	68	32
22191-16-12	G1"X11	20	12	66.2	11	68.5	41
22191-16-14	G1"X11	22	14	71.2	11	69.5	41
22191-16-16	G1"X11	25	16	76.7	11	75	41
22191-20-16	G1.1/4"X11	25	16	76.7	10	78	50
22191-20-20	G1.1/4"X11	32	20	93	10	89	50
22191-24-24	G1.1/2"X11	40	24	109.4	11.5	104	55
22191-32-32	G2"X11	50	32	131.8	15	125.3	70

Note: 1. For use with braided hoses.

2. If use with spiral hose, hose fitting series number is 22142-xx-xx

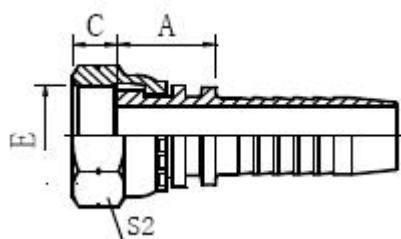

22211

英管内螺纹平面

BSP FEMALE FLAT SEAL

代号 P/N	螺纹 E THREAD E	软管 HOSE BORE		尺寸 DIMENSIONS			
		公称内径 DN	标号 DASH	A	C	S2	
22211-04-04	G1/4"X19	6	04	15.5	8	19	
22211-04-06	G1/4"X19	10	06	15.5	8	19	
22211-06-04	G3/8"X19	6	04	17	9	22	
22211-06-06	G3/8"X19	10	06	16.5	9	22	
22211-08-06	G1/2"X14	10	06	18	10.5	27	
22211-08-08	G1/2"X14	12	08	18.5	10.5	27	
22211-10-08	G5/8"X14	12	08	20	12	30	
22211-10-10	G5/8"X14	16	10	21	12	30	
22211-12-08	G3/4"X14	12	08	20.5	13.5	32	
22211-12-10	G3/4"X14	16	10	21.5	13.5	32	
22211-12-12	G3/4"X14	20	12	21.5	13.5	32	
22211-16-12	G1"X11	20	12	21.5	15.5	41	
22211-16-16	G1"X11	25	16	23	15.5	41	
22211-20-20	G1.1/4"X11	32	20	26	15.5	50	
22211-24-24	G1.1/2"X11	40	24	26.5	17.5	55	
22211-32-32	G2"X11	50	32	27	23	70	

Note: 1. For use with braided hoses.

2. If use with spiral hose, hose fitting series number is 22212-xx-xx

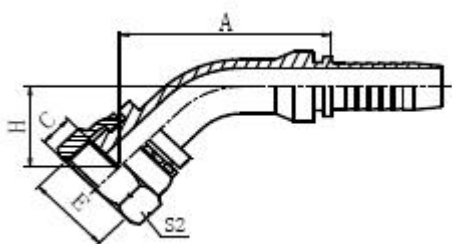

22241

45° 英管内螺纹平面

45° BSP FEMALE FLAT SEAT

代号 P/N	螺纹 E THREAD E	软管 HOSE BORE		尺寸 DIMENSIONS			
		公称内径 DN	标号 DASH	A	C	H	S2
22241-04-04	G1/4"X19	6	04	40.9	8	18.8	19
22241-06-06	G3/8"X19	10	06	45.3	9	21	22
22241-08-08	G1/2"X14	12	08	58.9	10.5	24	27
22241-12-12	G3/4"X14	20	12	77.4	13.5	30	32
22241-16-16	G1"X11	25	16	82.7	15.5	31.5	41
22241-20-20	G1.1/4"X11	32	20	97.3	15.5	36.6	50

Note: 1. For use with braided hoses.  
2. If use with spiral hose, hose fitting series number is 22242-x x-x x

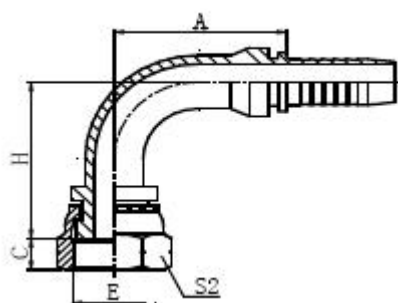

## 22291

90° 英管内螺纹平面

90° BSP FEMALE FLAT SEAT

代号 P/N	螺纹 E THREAD E	软管 HOSE BORE		尺寸 DIMENSIONS			
		公称内径 DN	标号 DASH	A	C	H	S2
22291-04-04	G1/4"X19	6	04	30	8	34.5	19
22291-06-06	G3/8"X19	10	06	35.3	9	41.25	22
22291-08-08	G1/2"X14	12	08	41	10.5	48	27
22291-12-12	G3/4"X14	20	12	65.5	13.5	63.5	32
22291-16-16	G1"X11	25	16	76.7	15.5	70	41
22291-20-20	G1.1/4"X11	32	20	91.5	15.5	82.5	50
22291-24-24	G1.1/2"X11	40	24	109.4	17.5	97.5	55

Note: 1. For use with braided hoses.  
2. If use with spiral hose, hose fitting series number is 22242-x x-x x

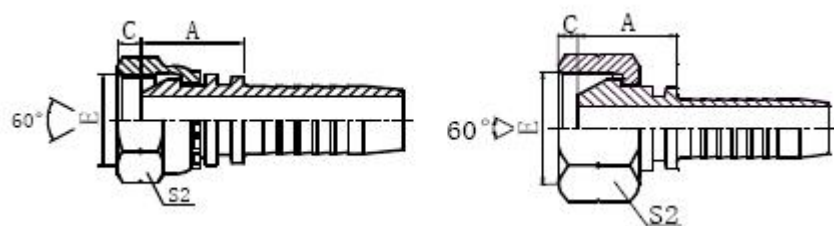

英管内螺纹 60° 外锥面

BSP FEMALE 60° CONE

22611

22611-T

代号 P/N	螺纹 E THREAD E	软管 HOSE BORE		尺寸 DIMENSIONS			
		公称内径 DN	标号 DASH	A	C	S2	
22611-04-04	G1/4"X19	6	04	18	5.5	19	
22611-06-04	G3/8"X19	6	04	19	6.3	22	
22611-06-05	G3/8"X19	8	05	19	6.3	22	
22611-06-06	G3/8"X19	10	06	19.5	6.3	22	
22611-08-06	G1/2"X14	10	06	21	7.5	27	
22611-08-08	G1/2"X14	12	08	21.5	7.5	27	
22611-10-08	G5/8"X14	12	08	22	9.5	30	
22611-10-10	G5/8"X14	16	10	23.5	9.5	30	
22611-12-08T	G3/4"X14	12	08	22	10.9	32	
22611-12-10	G3/4"X14	16	10	24	10.9	32	
22611-12-12	G3/4"X14	20	12	24	10.9	32	
22611-16-12T	G1"X11	20	12	24	11.7	41	
22611-16-16	G1"X11	25	16	27	11.7	41	
22611-20-20	G1.1/4"X11	32	20	30.5	11	50	
22611-24-20	G1.1/2"X11	32	20	29.5	13	55	
22611-24-24	G1.1/2"X11	40	24	31	13	55	
22611-32-24T	G2"X11	40	24	34	16	70	
22611-32-32	G2"X11	50	32	34	16	70	

Note: 1. For use with braided hoses.

2. If use with spiral hose, hose fitting series number is 22612-xx-xx



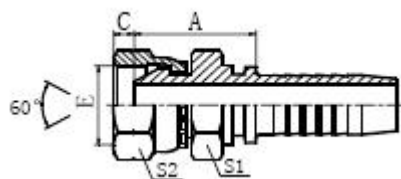

## 22611D

英管内螺纹 60°外锥面双六角

BSP FEMALE 60° CONE DOUGLE HEXAGON

代号 P/N	螺纹 E THREAD E	软管 HOSE BORE		尺寸 DIMENSIONS			
		公称内径 DN	标号 DASH	A	C	S1	S2
22611D-04-04	G1/4"X19	6	04	23.5	5.5	19	19
22611D-06-06	G3/8"X19	10	06	26.5	6.3	22	22
22611D-08-08	G1/2"X14	12	08	31	7.5	27	27
22611D-10-08	G5/8"X14	12	08	32	9.5	30	30
22611D-12-08	G3/4"X14	12	08	33	10.9	32	32
22611D-12-12	G3/4"X14	20	12	34	10.9	32	32
22611D-16-16	G1"X11	25	16	35.5	11.7	41	41
22611D-20-20	G1.1/4"X11	32	20	43.5	11	50	50

Note: 1. For use with braided hoses.

2. If use with spiral hose, hose fitting series number is 22612 D -x x-x x

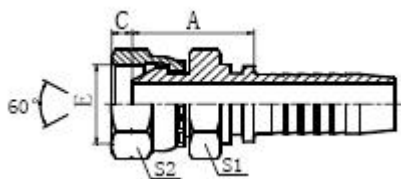

## 22611D-SM

英管内螺纹 60°外锥面双六角

BSP FEMALE 60° CONE DOUGLE HEXAGON

代号 P/N	螺纹 E THREAD E	软管 HOSE BORE		尺寸 DIMENSIONS			
		公称内径 DN	标号 DASH	A	C	S1	S2
22611D-04-04SM	G1/4"X19	6	04	23	5.5	14	19
22611D-06-06SM	G3/8"X19	10	06	25	6.3	17	22
22611D-08-08SM	G1/2"X14	12	08	38.5	7.5	22	27
22611D-10-08SM	G5/8"X14	12	08	30	9.5	22	30
22611D-12-08SM	G3/4"X14	12	08	32.1	10.9	27	32
22611D-12-12SM	G3/4"X14	20	12	32.5	10.9	27	32
22611D-16-16SM	G1"X11	25	16	36.3	11.7	32	41
22611D-20-20SM	G1.1/4"X11	32	20	41.5	11	41	50

Note: 1. For use with braided hoses.  
2. If use with spiral hose, hose fitting series number is 22612 -x x-x xSM

12611

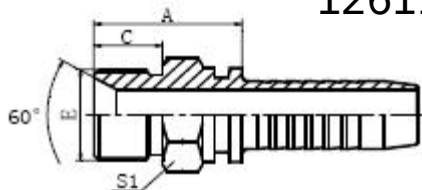

英管外螺纹 60°内锥面

BSP MALE 60° CONE SEAT

代号 P/N	螺纹 E THREAD E	软管 HOSE BORE		尺寸 DIMENSIONS			
		公称内径 DN	标号 DASH	A	C	S1	
12611-04-04	G1/4"X19	6	04	24.5	12	14	
12611-06-05	G3/8"X19	8	05	26	13.5	17	
12611-06-06	G3/8"X19	10	06	27.5	13.5	17	
12611-06-08	G3/8"X19	12	08	16.5	13.5	19	
12611-08-06	G1/2"X14	10	06	30.5	16	22	
12611-08-08	G1/2"X14	12	08	31	16	22	
12611-10-08	G5/8"X14	12	08	32.5	17.5	24	
12611-10-10	G5/8"X14	16	10	33.5	17.5	24	
12611-12-08	G3/4"X14	12	08	35.5	18.5	27	
12611-12-10	G3/4"X14	16	10	37	18.5	27	
12611-12-12	G3/4"X14	20	12	36.5	18.5	27	
12611-16-12	G1"X11	20	12	40.5	20.5	36	
12611-16-16	G1"X11	25	16	41.5	20.5	36	
12611-20-16	G1.1/4"X11	25	16	43.5	20.5	46	
12611-20-20	G1.1/4"X11	32	20	44.5	20.5	46	
12611-24-20	G1.1/2"X11	32	20	49	23	50	
12611-24-24	G1.1/2"X11	40	24	46	23	50	
12611-32-32	G2"X11	50	32	53.5	25.5	65	

Note: 1. For use with braided hoses.

2. If use with spiral hose, hose fitting series number is 12612-xx-xx

## 12611A

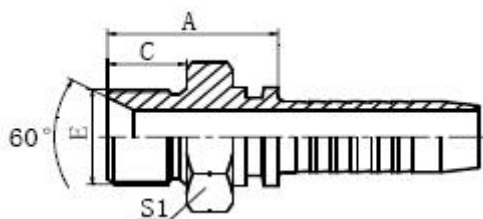

英管外螺纹 60°内锥面或六角端面组合垫密封的

双角接头

BSP MALE DOUBLE USE FOR 60° CONE SEAT OR  
BOUNDED SEAL

代号 P/N	螺纹 E THREAD E	软管 HOSE BORE		尺寸 DIMENSIONS			
		公称内径 DN	标号 DASH	A	C	S1	
12611A-04-04	G1/4"X19	6	04	24.5	12	19	
12611A-06-05	G3/8"X19	8	05	26	13.5	22	
12611A-06-06	G3/8"X19	10	06	28	13.5	22	
12611A-08-06	G1/2"X14	10	06	33	16	27	
12611A-08-08	G1/2"X14	12	08	33.5	16	27	
12611A-10-08	G5/8"X14	12	08	35	17.5	30	
12611A-10-10	G5/8"X14	16	10	36	17.5	30	
12611A-12-08	G3/4"X14	12	08	36.5	18.5	32	
12611A-12-10	G3/4"X14	16	10	37.5	18.5	32	
12611A-12-12	G3/4"X14	20	12	37.5	18.5	32	
12611A-16-12	G1"X11	20	12	42.5	20.5	41	
12611A-16-16	G1"X11	25	16	43.5	20.5	41	
12611A-20-16	G1.1/4"X11	25	16	45.5	20.5	50	
12611A-20-20	G1.1/4"X11	32	20	46.5	20.5	50	
12611A-24-24	G1.1/2"X11	40	24	49	23	55	
12611A-32-32	G2"X11	50	32	54.5	25.5	70	

Note: 1. For use with braided hoses.

2. If use with spiral hose, hose fitting series number is 12612A-xx-xx

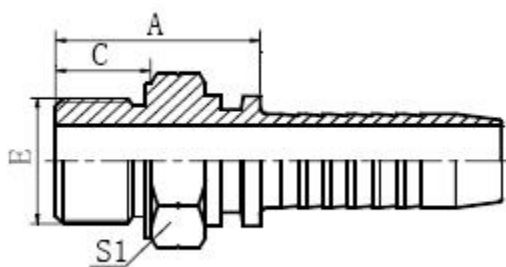

12211

英管外螺纹 O 形圈密封

BSP MALE O-RING SEAL

代号 P/N	螺纹 E THREAD E	软管 HOSE BORE		尺寸 DIMENSIONS			
		公称内径 DN	标号 DASH	A	C	S1	
12211-04-04	G1/4"X19	6	04	23.5	11	19	
12211-06-06	G3/8"X19	10	06	26.5	12	22	
12211-08-06	G1/2"X14	10	06	33.5	14	27	
12211-08-08	G1/2"X1	12	08	34	14	27	
12211-10-10	G5/8"X14	16	10	36	15.5	30	
12211-12-10	G3/4"X14	16	10	33.5	15.5	32	
12211-12-12	G3/4"X14	20	12	38	15.5	32	
12211-16-16	G1"X11	25	16	44.5	18.5	41	
12211-20-20	G1.1/4"X11	32	20	46	20	50	

Note: 1. For use with braided hoses.

2. If use with spiral hose, hose fitting series number is 12212-x-x-x-x

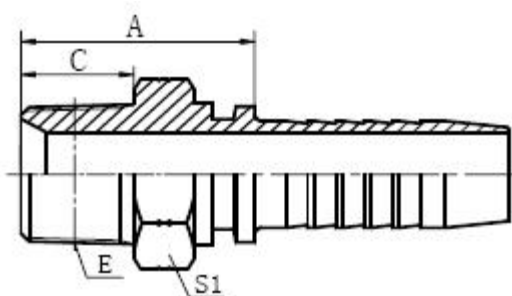

13011-SP

英锥管外螺纹

BSPT MALE

代号 P/N	螺纹 E THREAD E	软管 HOSE BORE		尺寸 DIMENSIONS			
		公称内径 DN	标号 DASH	A	C	S1	
13011-04-04SP	R1/4"X19	6	04	27	14.5	17	
13011-04-05SP	R1/4"X19	8	05	25	15.4	17	
13011-04-06SP	R1/4"X19	10	06	27	14.5	17	
13011-06-04SP	R3/8"X19	6	04	27.5	15	19	
13011-06-06SP	R3/8"X19	10	06	27.5	15	19	
13011-08-06SP	R1/2"X14	10	06	34.5	20	22	
13011-08-08SP	R1/2"X14	12	08	35	20	22	
13011-08-10SP	R1/2"X14	16	10	38	20	24	
13011-08-12SP	R1/2"X14	20	12	38	20	27	
13011-12-08SP	R3/4"X14	12	08	37	20	30	
13011-12-10SP	R3/4"X14	16	10	38	20	30	
13011-12-12SP	R3/4"X14	20	12	38.5	20	30	
13011-16-12SP	R1"X11	20	12	44	25.5	36	
13011-16-16SP	R1"X11	25	16	45	25.5	36	
13011-20-20SP	R1.1/4"X11	32	20	49.5	26.5	46	
13011-24-24SP	R1.1/2"X11	40	24	51.5	26.5	50	
13011-32-24SP	R2"X11	50	32	57	30	65	
13011-32-32SP	R2"X11	50	32	57	30	65	

Note: 1. For use with braided hoses.

2. If use with spiral hose, hose fitting series number is 13012-xx-xx

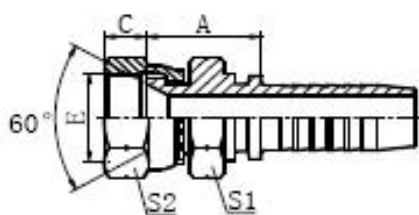

29611

日本英制内螺纹 60°内锥面

JIS GAS FEMALE 60° CONE SEAT JIS B8363

代号 P/N	螺纹 E THREAD E	软管 HOSE BORE		尺寸 DIMENSIONS			
		公称内径 DN	标号 DASH	A	C	S1	S2
29611-04-04	G1/4"X19	6	04	21	8	19	19
29611-06-04	G3/8"X19	6	04	24	9	22	22
29611-06-06	G3/8"X19	10	06	23	9	22	22
29611-08-06	G1/2"X14	10	06	28	12	27	27
29611-08-08	G1/2"X14	12	08	26.5	12	27	27
29611-10-10	G5/8"X14	16	10	31	11.5	30	30
29611-12-10	G3/4"X14	16	10	28.5	13.5	32	32
29611-12-12	G3/4"X14	20	12	28.5	13.5	32	32
29611-16-16	G1"X11	25	16	32	16	41	41
29611-20-20	G1.1/4"X11	32	20	43	18.5	50	50
29611-24-24	G1.1/2"X11	40	24	43.5	19	55	55
29611-32-32	G2"X11	50	32	46.5	23	70	70

Note: 1. For use with braided hoses.

2. If use with spiral hose, hose fitting series number is 29612-x-x-x-x

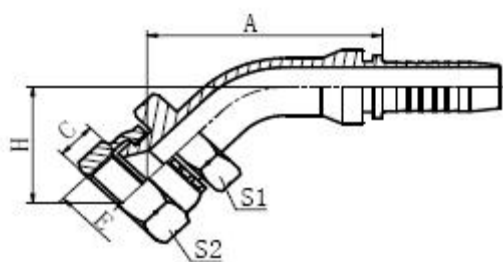

29641

45° 日本英制内螺纹 60°内锥面

45° JIS GAS FEMALE 60° CONE SEAT JIS

B8363

代号 P/N	螺纹 E THREAD E	软管 HOSE BORE		尺寸 DIMENSIONS				
		公称内径 DN	标号 DASH	A	C	H	S1	S2
29641-04-04	G1/4"X19	6	04	43.4	8	21.3	19	19
29641-06-06	G3/8"X19	10	06	48.9	9	24.6	22	22
29641-08-08	G1/2"X14	12	08	62.5	12	27.5	27	27
29641-12-12	G3/4"X14	20	12	81.3	13.5	33.9	32	32
29641-16-16	G1"X11	25	16	87.3	16	36	41	41
29641-20-20	G1.1/4"X1	32	20	107.3	18.5	46.5	50	50
29641-24-24	G1.1/2"X1	40	24	122.8	19	50.	55	55
29641-32-32	G2"X11	50	32	143	23	60	70	70

Note: 1. For use with braided hoses.

2. If use with spiral hose, hose fitting series number is 29642-xx-xx



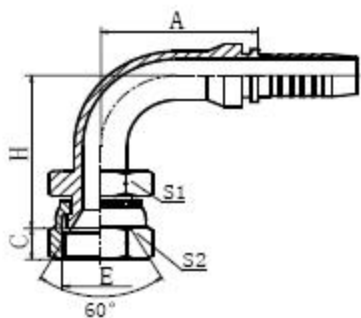

## 29691

90° 日本英制内螺纹 60°内锥面

90° JIS GAS FEMALE 60° CONE SEAT JIS B8363

代号 P/N	螺纹 E THREAD E	软管 HOSE BORE		尺寸 DIMENSIONS				
		公称内径 DN	标号 DASH	A	C	H	S1	S2
29691-04-04	G1/4"X19	6	04	30	8	38	19	19
29691-04-05	G1/4"X19	8	05	33	8	41	19	19
29691-06-06	G3/8"X19	10	06	35.3	9	45.75	22	22
29691-08-08	G1/2"X14	12	08	41	12	53	27	27
29691-10-10	G5/8"X14	16	10	56.5	11.5	61	30	30
29691-12-12	G3/4"X14	20	12	65.5	13.5	69	32	32
29691-16-16	G1"X11	25	16	76.7	16	76.5	41	41
29691-20-20	G1.1/4"X11	32	20	91.5	18.5	92.5	50	50
29691-24-24	G1.1/2"X11	40	24	109.4	19	110.5	55	55
29691-32-32	G2"X11	50	32	131.8	23	133.8	70	70

Note: 1. For use with braided hoses.

2. If use with spiral hose, hose fitting series number is 29692-xx-xx

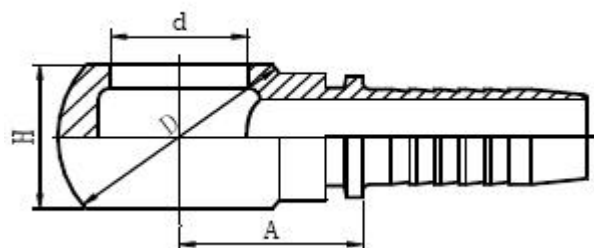

72011

英制铰接体

BSP BANJO

代号 P/N	螺栓 BOLT	软管 HOSE BORE		尺寸 DIMENSIONS			
		公称内径 DN	标号 DASH	A	d	D	H
72011-04-04	G1/4"X19	6	04	19.5	13.3	24	15
72011-06-05	G3/8"X19	8	05	22	16.7	29	20
72011-06-06	G3/8"X19	10	06	22	16.7	29	20
72011-08-06	G1/2"X14	10	06	27.5	21	38	25
72011-08-08	G1/2"X14	12	08	28	21	28	25
72011-08-10	G1/2"X14	16	10	29	21	38	25
72011-10-10	G5/8"X14	16	10	28	23	40	27
72011-12-12	G3/4"X14	20	12	32	26.5	48	31
72011-16-08	G1"X11	12	08	40	33.3	60	42
72011-16-12	G1"X11	20	12	40	33.3	60	42
72011-16-16	G1"X11	25	16	41	33.3	60	42

Note: 1. For use with braided hoses.

2. If use with spiral hose, hose fitting series number is 72012-xx-xx

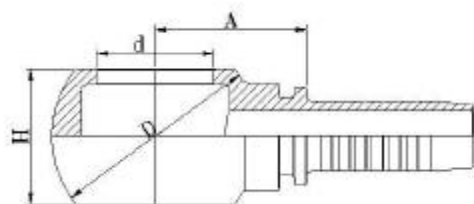

## 720B

英制铰螺栓

BSP BOLT

代号 P/N	螺纹 E THREAD E	软管 HOSE BORE		尺寸 DIMENSIONS			
		公称内径 DN	标号 DASH	A	d	D	H
720B-04-04	G1/4"X19			19.5	13.3	24	15
720B-06-05	G3/8"X19			22	16.7	29	20
720B-06-06	G3/8"X19			22	16.7	29	20
720B-08-06	G1/2"X14			27.5	21	38	25
720B-08-08	G1/2"X14			28	21	28	25
720B-08-10	G1/2"X14			29	21	38	25
720B-10-10	G5/8"X14			28	23	40	27
720B-12-12	G3/4"X14			32	26.5	48	31
720B-16-08	G1"X11			40	33.3	60	42
720B-16-12	G1"X11			40	33.3	60	42
720B-16-16	G1"X11			41	33.3	60	42

Note: 1. For use with braided hoses.  
2. If use with spiral hose, hose fitting series number is 72012-xx-xx

## **NOTES**

The drawings in this catalogue are for reference only, and their dimensions and proportions may be a little different from those of the real products.

Products included in this catalogue don't refer to all, so if customers are interested in other products, please don't hesitate to contact our company for further information.

Our company has made much effort to record the correct data in this publication. However, in order to promote our products, we may make some changes of their size or description, which haven't been shown yet. We reserve the rights for explanation, but sorry for no further notice to customer the change of products' design, description or even stop of some products' manufacture in future.